

External Rewinder

ER4/210

Operator's Manual - Translation of the Original Version for the following products

Part.-No.	Description	Type
5540750	External Rewinder	ER4/210

Edition: 08/2010 - Part.-No. 9008729

Copyright

This documentation as well as translation hereof are property of cab Produkttechnik GmbH & Co. KG. The replication, conversion, duplication or divulgement of the whole manual or parts of it for other intentions than its original intended purpose - in particular the procurement of spare parts for products sold by cab - demand the previous written authorization by cab.

Trademark

Centronics® is a registered trademark of the Data Computer Corporation.
Microsoft® is a registered trademark of the Microsoft Corporation.
Windows 2000®, 2003®, XP® are registered trademarks of the Microsoft Corporation.
TrueType™ is a registered trademark of Apple Computer, Inc.

Editor

Regarding questions or comments please contact cab Produkttechnik GmbH & Co. KG.

Topicality

Due to the constant further development of our products discrepancies between documentation and product can occur. Please check www.cabgmbh.com for the latest update.

Terms and conditions

Deliveries and performances are effected under the General conditions of sale of cab.

Germany

cab Produkttechnik
GmbH & Co KG
Postfach 1904
D-76007 Karlsruhe
Wilhelm-Schickard-Str. 14
D-76131 Karlsruhe
Telefon +49 721 6626-0
Telefax +49 721 6626-249
www.cab.de
info@cab.de

France

cab technologies s.a.r.l.
F-67350 Niedermodern
Téléphone +33 388 722 501
www.cab.de
info@cab-technologies.fr

España

cab España S.L.
E-08304 Montaró (Barcelona)
Teléfono +34 937 414 605
www.cab.de
info@cabsi.com

USA

cab Technology Inc.
Tyngsboro MA, 01879
Phone +1 978 649 0293
www.cabtechn.com
info@cabtechn.com

South Afrika

cab Technology (Pty.) Ltd.
2125 Randburg
Phone +27 11-886-3580
www.cab.de
info@cabtechn.co.za

Asia 亞洲分公司

希愛比科技股份有限公司
cab Technology Co., Ltd.
台灣台北縣中和市中正路 700 號 01-8
Junghe 23552, Taipei, Taiwan
電話 Phone +886 2 8227 3966
網址 www.cabasia.net
郵箱 cabasia@cab.de

China 中國

穗博(上海)貿易有限公司
cab (Shanghai) Trading Co., Ltd
上海市延安西路 2299 弄 11C60 室
電話 Phone +86 21 6236-3161
郵箱 cabasia@cab.de

Representatives in other countries on request.

1	Introduction	4
1.1	Instructions	4
1.2	Intended Use	4
1.3	Safety Instructions	5
1.4	Environment	5
2	Product Description	6
2.1	Function	6
2.2	Technical Specification	6
2.3	Device Overview	7
3	Start-Up	8
3.1	Contents of Delivery	8
3.2	Mount the Connecting Set	8
3.3	Connecting to Power Supply	9
4	Alignment	9
4.1	Sighting the External Rewinder to the Printer	9
4.2	Selection of the Rewind Direction	10
4.3	Alignment the Guide Axle	10
5	Operation	11
5.1	Rewinding Directly onto the Rewind Axle	11
5.2	Rewinding onto 40 mm (1.6 in) Cardboard Core	12
5.3	Rewinding onto 76 mm (3 in) Cardboard Core	13
6	EC - Declaration of Conformity	14

1.1 Instructions

Important information and instructions in this documentation are designated as follows:

**Danger!**

Draws your attention to an exceptionally grave, impending danger to your health or life.

**Warning!**

Indicates a hazardous situation that could lead to injuries or material damage.

**Attention!**

Draws attention to possible dangers, material damage or loss of quality.

**Notice!**

Gives you tips. They make a working sequence easier or draw attention to important working processes.

**Environment!**

Gives you tips on protecting the environment.



Handling instruction



Reference to section, position, illustration number or document.



Option (accessories, peripheral equipment, special fittings).

1.2 Intended Use

- The device is manufactured in accordance with the current technological status and the recognized safety rules. However, danger to the life and limb of the user or third parties and/or damage to the device and other tangible assets can arise during use.
- The device may only be used for its intended purpose and if it is in perfect working order, and it must be used with regard to safety and dangers as stated in the operating manual.
- The device is to use only in combination with a MACH4 label printer.
- The device is intended exclusively for rewinding suitable materials that have been approved by the manufacturer. Any other use or use going beyond this shall be regarded as improper use. The manufacturer/supplier shall not be liable for damage resulting from unauthorized use; the user shall bear the risk alone.
- Usage for the intended purpose also includes complying with the operating manual, including the manufacturer's maintenance recommendations and specifications.

**Notice!**

The complete documentation is currently in the Internet.

1.3 Safety Instructions

- The device may only be used in a dry environment, do not expose it to moisture (sprays of water, mists, etc.).



Warning!

During operation, the rotating parts of the device are freely accessible. When working on the device wear tightly fitting clothes and tie up long hair. Loosely hanging pieces or long hair can get caught in parts of the device.



Attention!

Switch off the device in case of changing the turn direction.



Warning!

Do not try to manipulate or repair parts they are not described in the manuals of the external rewinder or the printer.

1.4 Environment



Obsolete devices contain valuable recyclable materials that should be sent for recycling.

- ▶ Send to suitable collection points, separately from residual waste.
- ▶ Send the parts for recycling.

2.1 Function

The External Rewinders are peripheral devices for transfer printers MACH4, . During processing of large print jobs it is possible to take up and rewind large label roles independently of the printer. An adjustable guide axle ensures that the label strip is led horizontally from the printer into the rewinder. For a correct alignment of the external rewinder with the printer use the included connecting set.

2.2 Technical Specification

		ER4/210
Max. Material Width		120 mm (4.7 in)
Max. Rewinder Diameter		210 mm (8.3 in)
Core Diameter		40 mm (1.6 in) on rewind axle 40 mm (1.6 in) on cardboard core 76 mm (3 in) on cardboard core with adapter
Rewind Speed		max. 300 mm/s (12 in/s)
Label Rewinding		Labels in- or outside
Dimensions	Height	280 mm (11 in)
	Width	260 mm (10.2 in)
	Depth	270 mm (10.6 in)
Weight		5.0 kg (11 lb)
Operating Temperature		10 - 35 °C (50°F - 95°F) at 30 to 85% humidity non condensing
Storage and Transport Temperature		-20 - 50 °C (4°F - 122°F) at 10 to 85% humidity non condensing
Operating Voltage		110 - 240 V~ / 50 - 60 Hz

2.3 Device Overview

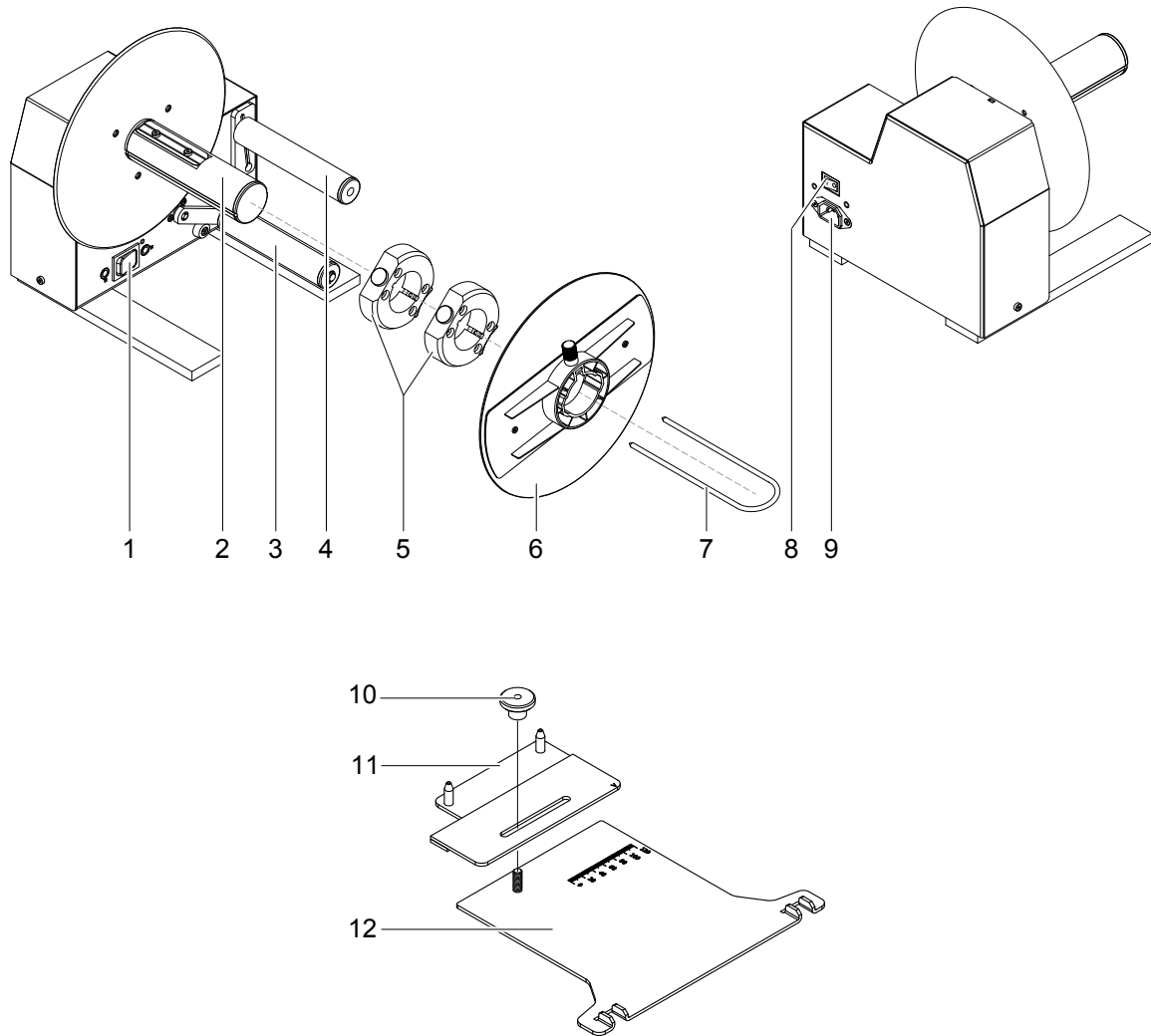

Figure 1 Device overview

- | | | | |
|---|---------------------------|----|--------------------|
| 1 | Switch Rotating Direction | 7 | Clamp |
| 2 | Rewind Axle | 8 | Power Switch |
| 3 | Roll | 9 | Power Input Module |
| 4 | Guide Axle | 10 | Knurled Nut |
| 5 | Rewind Adapter | 11 | Connection Plate |
| 6 | Plate | 12 | Adapter Plate |

3.1 Contents of Delivery

- ▶ Check the external rewinder for damages in transit and totality.

Contents of delivery:

- External Rewinder
- 2 Rewind Adapters
- Plate
- Connection Set
- Power Cable
- Documentation



Notice!

Retain packing material for later use !

3.2 Mount the Connecting Set

The connecting set is essential to get a defined and fixed position of the external rewinder ER4/210 to the printer MACH4.

1. Put the two guidings (4) into the suitable holes (5) on the bottom side of the printer.
2. On the connecting plate are two pins (2) mounted to put in the holes (1) at the feet of the external rewinder.
- (▶ 4.1 Sighting the external rewinder to the printer)
3. Fix the position of the printer and external rewinder via the tighten the knurled nut (3).

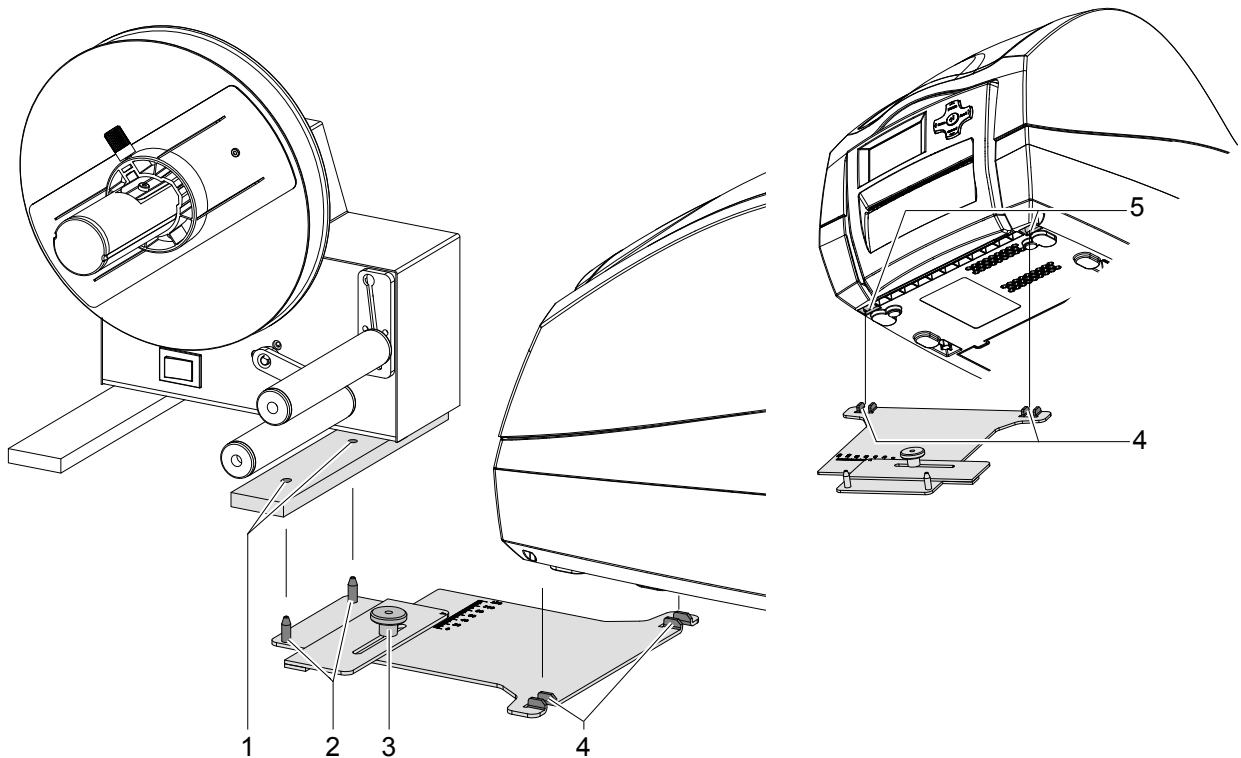

Figure 2 Mounting external rewinder - connecting set - printer

3.3 Connecting to Power Supply

The rewinder is equipped with a wide range power unit (100-240V~), so it is possible to use the printer both with a voltage of 230V~/50 Hz and with a voltage of 115V~/60 Hz without making changes to the printer.



Warning!

Risk of injury by rotating engine parts.

Make sure the power switch (1) is in position „O“ (OFF) before connecting the printer to a power supply !
When switching on the Rewinder starts immediately without or with loose material

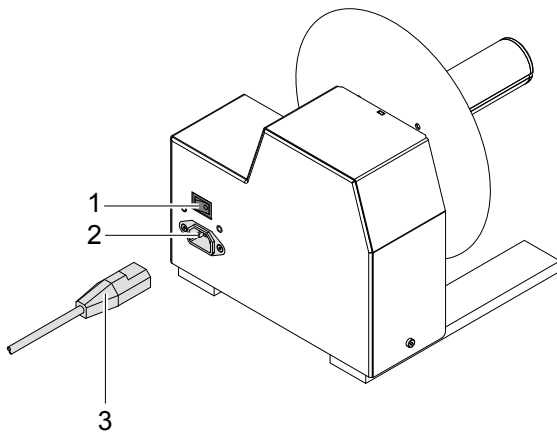

Figure 3 Power supply

The rewinder is ready for use, if the power cable (3) supplied in the accessories is inserted into a power supply connector (2) and the cable is contacted to a grounded outlet.

4 Alignment

4.1 Sighting the External Rewinder to the Printer

The print and dispense of the label are orientated to the center at the MACH4 printer.

The position of the rewinded labels at the external rewinder are orientated to the plate (2) side of the rewind axle. So it's essential to adjust the external rewinder to the printer depend of label material broadness.

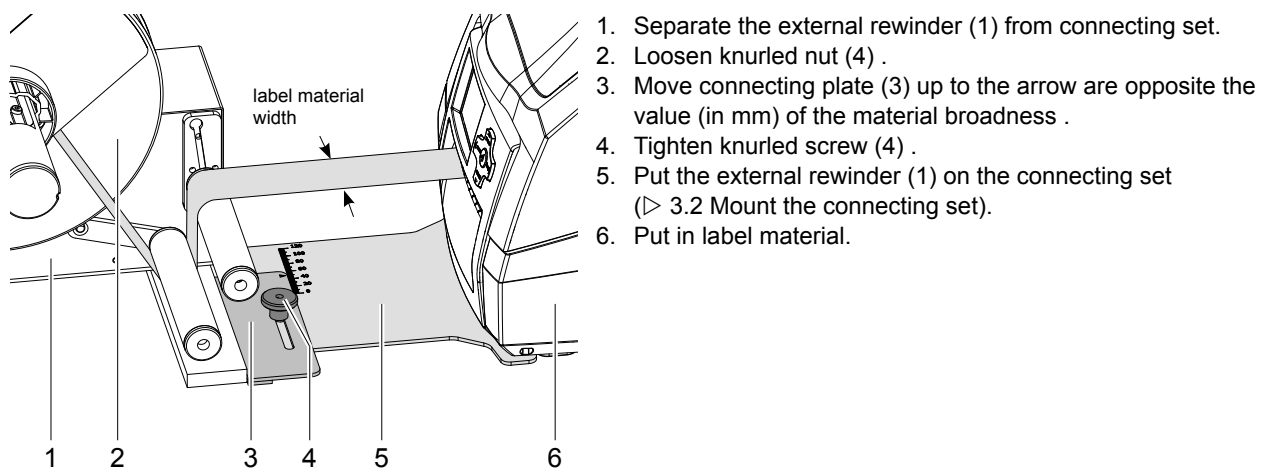

Figure 4 Sighting the external rewinder to the printer

4.2 Selection of the Rewind Direction

The selection of the rewind direction is depend of using an inside or outside wound label.

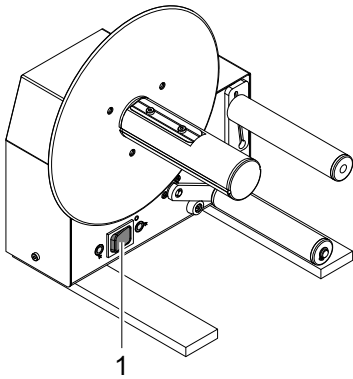

Figure 5 Direction of rewinding

► Turn off the rewinder and set the switch (1) to the required direction of rewinding:



Rewinding with labels inside



Rewinding with labels outside

4.3 Alignment the Guide Axle

Depend of the used printer the guide axle should be aligned so, that the label strip is led horizontally from the printer to the rewinder.

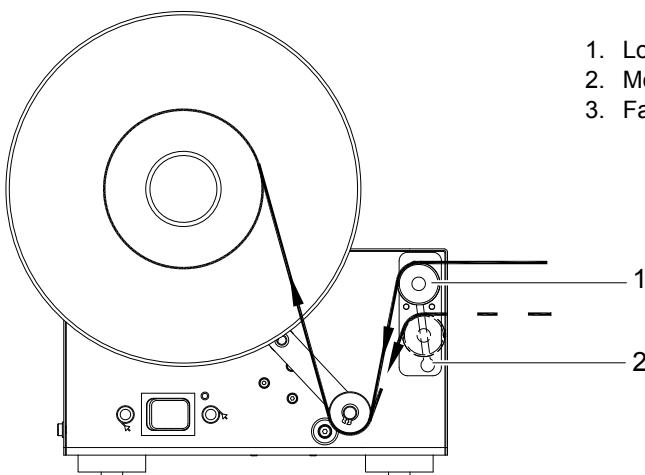

1. Loosen the guide axle (1) by turning it counterclockwise.
2. Move it in the guide plate (2) up to the desired positioning.
3. Fasten the guide axle (1) by turning it clockwise.

Figure 6 Alignment the guide axle

5.1 Rewinding Directly onto the Rewind Axle

i Notice!
First remove the spring (2) from the rewind axle!



Warning!
Risk of injury by rotating engine parts.
When switching on the Rewinder starts immediately and winds to the material is tightened.

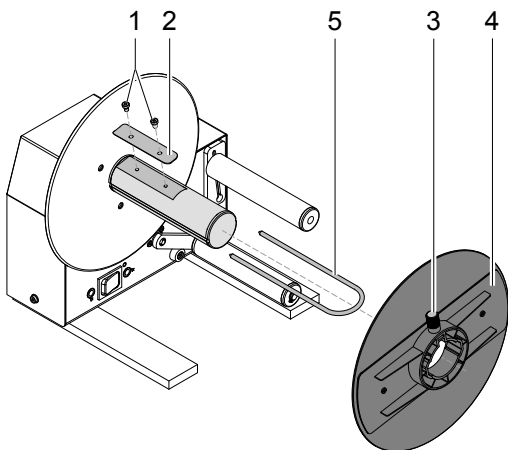

1. Loosen the screws (1) and remove the spring (2).

i Notice!
Consider the required direction of rewinding :
- The broken line is valid for inside wound labels.
- The full line is valid for outside wound labels.

2. Feed the label strip over the guide axle (9) and under the roller (8) to the rewind axle (7).
3. Attach the label strip appropriately to the rewind axle by sliding the clamp (5) over the label strip with the clamp set in the groove of the rewind axle (7).
4. Slide the clamp (5) as far as possible towards the disc (6).
5. Slide the plate (4) onto the rewind axle so that it slightly touches the label strip. The label strip must be able to move between the disc and the plate.
6. Tighten the knurled screw (3) on the plate.
7. Switch on the rewinder on the power switch.

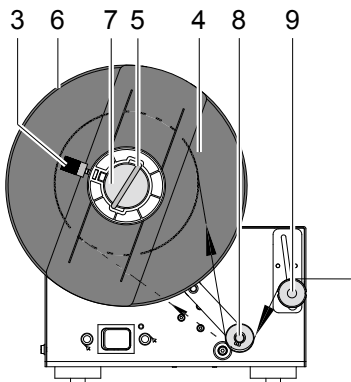

Figure 7 Direct rewinding

5.2 Rewinding onto 40 mm (1.6 in) Cardboard Core



Notice!

Make sure that the spring (1) is mounted on the rewind axle (2)!
Consider that the cardboard core (3) should be about 1 mm (0.04 in) broader than the label strip



Warning!

Risk of injury by rotating engine parts.
When switching on the Rewinder starts immediately and winds to the material is tightened.

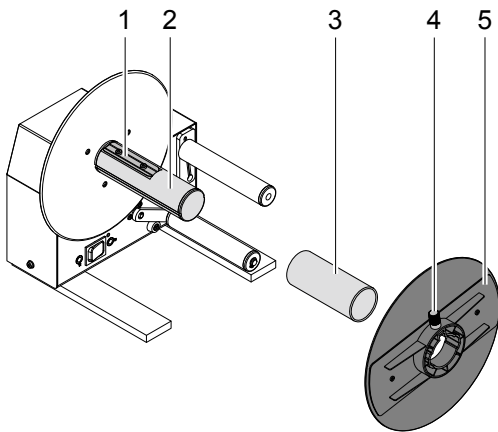

1. Put the cardboard core (3) on the rewind axle (2).



Notice!

Consider the required direction of rewinding :
- The broken line is valid for inside wound labels.
- The full line is valid for outside wound labels.

2. Feed the label strip over the guide axle (8) and under the roller (7) up to the cardboard core (3).
3. Affix the end of the label strip with consideration of the selected rewinding direction to the cardboard core using adhesive tape or label.
4. Slide the plate (5) with the knurled screw outward onto the rewind axle until it stops.

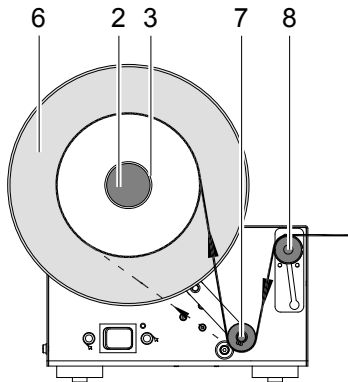

Notice!

When using small labels it is possible that the cardboard core not covers the spring over the whole length. In this case the groove on the plate must be aligned so that it fits on the spring of the rewind axle.

5. Tighten the knurled screw (4) on the plate.
6. Switch on the rewinder on the power switch.

Figure 9 Rewinding onto 40 mm (1.6 in) cardboard core (drawing below without plate)

5.3 Rewinding onto 76 mm (3 in) Cardboard Core



Notice!

First remove the spring from the rewind axle!

Consider that the cardboard core (3) should be about 1 mm (0.04 in) broader than the label strip.



Warning!

Risk of injury by rotating engine parts.

When switching on the Rewinder starts immediately and winds to the material is tightened.

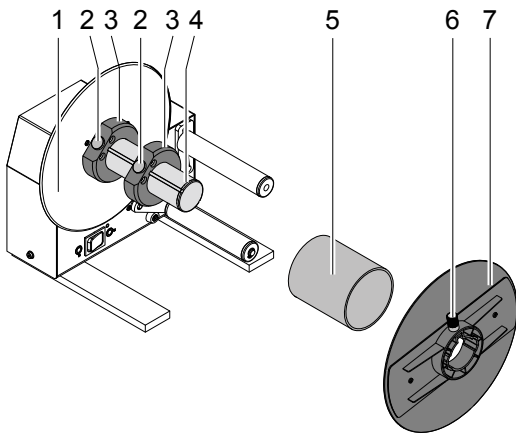

1. Put the first rewind adapter (3) onto the rewind axle (4) and slide it up to the disc (1) until it stops. Make sure that the knurled screw (2) of the rewind adapter is led in the groove of the rewind axle. Tighten the knurled screw (2).
2. Put the second rewind adapter (3) onto the rewind axle (4) and slide it towards the first adapter until the clearance between the outer edge of it and the disc (1) is a little less than the width of the cardboard core. Tighten the knurled screw (2).



Notice!

Consider the required direction of rewinding :

- The broken line is valid for inside wound labels.
- The full line is valid for outside wound labels.

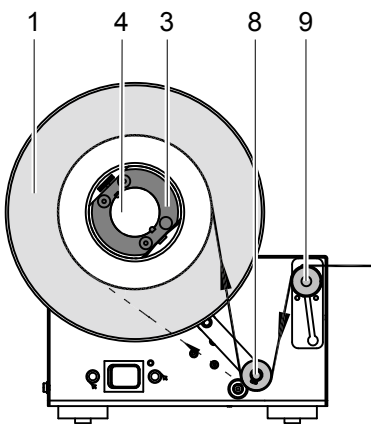

3. Put the cardboard core (5) on the rewind axle (2).
4. Feed the label strip over the guide axle (9) and under the roller (8) up to the cardboard core (5).
5. Affix the end of the label strip with consideration of the selected rewinding direction to the cardboard core using adhesive tape or label.
6. Slide the plate (7) with the knurled screw outward onto the rewind axle until it stops.
7. Tighten the knurled screw (6) on the plate.
8. Switch on the rewinder on the power switch.

Figure 9 Rewinding onto 76 mm (3 in) cardboard core (drawing below without plate)



Gesellschaft für Computer-
und Automations-
Bausteine mbH & Co KG
Wilhelm-Schickard-Str. 14
D-76131 Karlsruhe,
Germany

EC Declaration of Conformity

We declare herewith that as a result of the manner in which the device designated below was designed, the type of construction and the devices which, as a result have been brought on to the general market comply with the relevant fundamental regulations of the EU Rules for Safety and Health. In the event of any alteration which has not been approved by us being made to any device as designated below, this statement shall thereby be made invalid.

Device:	External Rewinder
Type:	ER4/210
Applied EU Regulations and Norms:	Applied Norms:
Directive 2006/42/EC on machinery	<ul style="list-style-type: none"> • EN ISO 12100-1:2003 • EN ISO 12100-2:2003 • EN ISO 14121-1:2007 • EN 60950-1:2006 • EN 61558-1:2005
Directive 2004/108/EC relating to electromagnetic compatibility	<ul style="list-style-type: none"> • EN 55014-1:2006 • EN 55014-2:1997+A1:2001 • EN 61000-3-2:2006 • EN 61000-3-3:1995+A1:2001+A2:2005
Person authorised to compile the technical file ::	Erwin Fascher Am Unterwege 18/20 99610 Sömmerda
Signed for, and on behalf of the Manufacturer :	Sömmerda, 23.08.2010
cab Produkttechnik Sömmerda Gesellschaft für Computer- und Automationsbausteine mbH 99610 Sömmerda	 Erwin Fascher Managing Director