

External Rewinder

ER4 / ER6 / ER8

Made in Germany

Part No.	Description	Type
5948100	External Rewinder	ER4/210
5946090	External Rewinder	ER4/300
5946420	External Rewinder	ER6/300
5945804	External Rewinder	ER8/300

Edition: 10/2017 - **Part No.** 9008926

Copyright

This documentation as well as translation hereof are property of cab Produkttechnik GmbH & Co. KG.

The replication, conversion, duplication or divulgement of the whole manual or parts of it for other intentions than its original intended purpose - in particular the procurement of spare parts for products sold by cab - demand the previous written authorization by cab.

Trademark

Windows is a registered trademark of the Microsoft Corporation.

Editor

Regarding questions or comments please contact cab Produkttechnik GmbH & Co. KG.

Topicality

Due to the constant further development of our products discrepancies between documentation and product can occur. Please check www.cab.de for the latest update.

Terms and conditions

Deliveries and performances are effected under the General conditions of sale of cab.

Germany

cab Produkttechnik
GmbH & Co KG
Postfach 1904
D-76007 Karlsruhe
Wilhelm-Schickard-Str. 14
D-76131 Karlsruhe
Telefon +49 721 6626-0
Telefax +49 721 6626-249
www.cab.de
info@cab.de

France

cab technologies s.a.r.l.
F-67350 Niedermodern
Téléphone +33 388 722 501
www.cab.de/fr
info.fr@cab.de

USA

cab Technology Inc.
Tyngsboro MA, 01879
Phone +1 978 649 0293
www.cab.de/us
info.us@cab.de

Asia 亚洲

cab Technology Co., Ltd.
希愛比科技股份有限公司
Junghe, Taipei, Taiwan
Phone +886 2 8227 3966
www.cab.de/tw
info.asia@cab.de

China 中国

cab (Shanghai)Trading Co., Ltd.
乾博(上海)贸易有限公司
Phone +86 21 6236-3161
www.cab.de/cn
info.cn@cab.de

Representatives in other countries on request

1	Introduction	4
1.1	Notes	4
1.2	Intended Use	4
1.3	Safety Instructions.....	5
1.4	Environment	5
2	Product Description.....	6
2.1	Function	6
2.2	Technical Data.....	6
2.3	Device Overview	7
3	Start-Up	8
3.1	Contents of Delivery.....	8
3.2	Connecting to Power Supply.....	8
4	Settings	9
4.1	Setting the Winding Direction.....	9
4.2	Adjusting the Guide Axle.....	9
5	Operation	10
5.1	Rewinding Directly onto the Rewind Axle.....	10
5.2	Rewinding onto 40 mm (1.6 in) Cardboard Core	11
5.3	Rewinding onto 76 mm (3 in) Cardboard Core	12
6	Licences.....	13
6.1	EU Declaration of Conformity.....	13
6.2	FCC.....	14

1.1 Notes

Important information and instructions are designated as follows:



Danger!

Draws attention to an exceptionally great, imminent danger to your health or life due to hazardous voltages.



Danger!

Draws attention to a danger with high risk which, if not avoided, may result in death or serious injury.



Warning!

Draws attention to a danger with medium risk which, if not avoided, may result in death or serious injury.



Caution!

Draws attention to a danger with low risk which, if not avoided, may result in minor or moderate injury.



Attention!

Draws attention to potential risks of property damage or loss of quality.



Note!

Advices to make work routine easier or on important steps to be carried out.



Environment!

Advices on protecting the environment.



Handling instruction



Reference to section, position, illustration number or document.



Option (accessories, peripheral equipment, special fittings).

Time Information in the display.

1.2 Intended Use

- The device is manufactured in accordance with the current technological status and the recognized safety rules. However, danger to the life and limb of the user or third parties and/or damage to the device and other tangible assets can arise during use.
- The device may only be used for its intended purpose and if it is in perfect working order, and it must be used with regard to safety and dangers as stated in the operating manual.
- The device is intended exclusively for rewinding suitable materials that have been approved by the manufacturer. Any other use or use going beyond this shall be regarded as improper use. The manufacturer/supplier shall not be liable for damage resulting from unauthorized use; the user shall bear the risk alone.
- Usage for the intended purpose also includes complying with the operating manual, including the manufacturer's maintenance recommendations and specifications.



Note!

The complete documentation can also currently be found in the Internet.

1.3 Safety Instructions

- The device may only be used in a dry environment, do not expose it to moisture (sprays of water, mists, etc.).
- Do not try to manipulate or repair parts they are not described in the manuals of the external rewinder or the printer.



Caution!

Risk of injury by rotating parts!

During operation, rotating parts are freely accessible.

- ▶ **Ensure that people’s clothing, hair, jewelry etc. do not come into contact with the exposed rotating parts.**



Attention!

Risk of gear defect!

- ▶ **Switch off the device before changing the winding direction.**

1.4 Environment



Obsolete devices contain valuable recyclable materials that should be sent for recycling.

- ▶ Send to suitable collection points, separately from residual waste.
- ▶ Send the parts for recycling.

2.1 Function

The External Rewinders are peripheral devices for transfer printers of different manufacturers.

During processing of large print jobs it is possible to take up and rewind large label roles independently of the printer. An adjustable guide axle ensures that the label strip is led horizontally from each printer into the rewinder.

For a correct alignment of the External Rewinders with the printers of the A+- and XC-Series Adapter Kits are offered.

2.2 Technical Data

		ER4/210	ER4/300	ER6/300	ER8/300
Max. Material Width		120 mm (4.7 in)	120 mm (4.7 in)	180 mm (7.1 in)	235 mm (9.2 in)
Max. Rewinder Diameter		205 mm (8.1 in)	300 mm (11.8 in)	300 mm (11.8 in)	300 mm (11.8 in)
Core Diameter		40 mm (1.6 in) on rewind axle 40 mm (1.6 in) on cardboard core 76 mm (3 in) on cardboard core with adapter			
Rewind Speed		max. 300 mm/s (12 in/s)			
Label Rewinding		Labels in- or outside			
Dimensions	Height	280 mm (11)	350 mm (13.8)	350 mm (13.8)	350 mm (13.8)
	Width	260 mm (10.2)	280 mm (11)	340 mm (13.4)	395 mm (15.5)
	Depth	270 mm (10.6)	390 mm (15.3)	390 mm (15.3)	390 mm (15.3)
Weight		5,0 kg (11 lb)	6,0 kg (13.2 lb)	6,3 kg (13.9 lb)	6,6 kg (14.6 lb)
Operating Temperature		5 - 40 °C, at humidity 10 - 85 % not condensing			
Storage Temperature		0 - 60 °C, at humidity 20 - 80 % not condensing			
Transport Temperature		-25 - 60 °C, at humidity 20 - 80 % not condensing			
Operating Voltage		110 - 240 V~ / 50 - 60 Hz			

Table 1 Technical Data

2.3 Device Overview

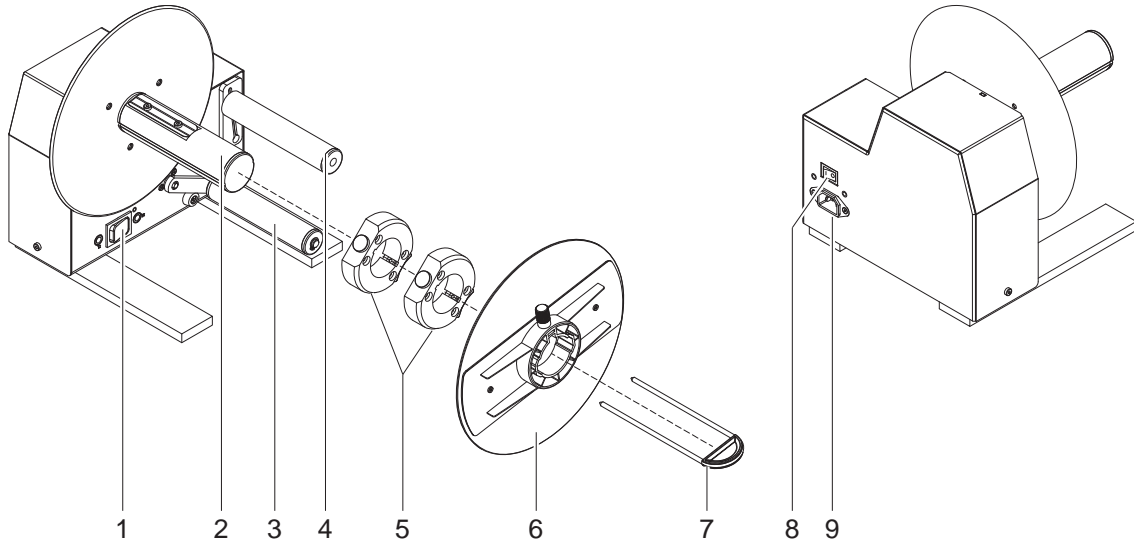

Figure 1 Overview ER4/210

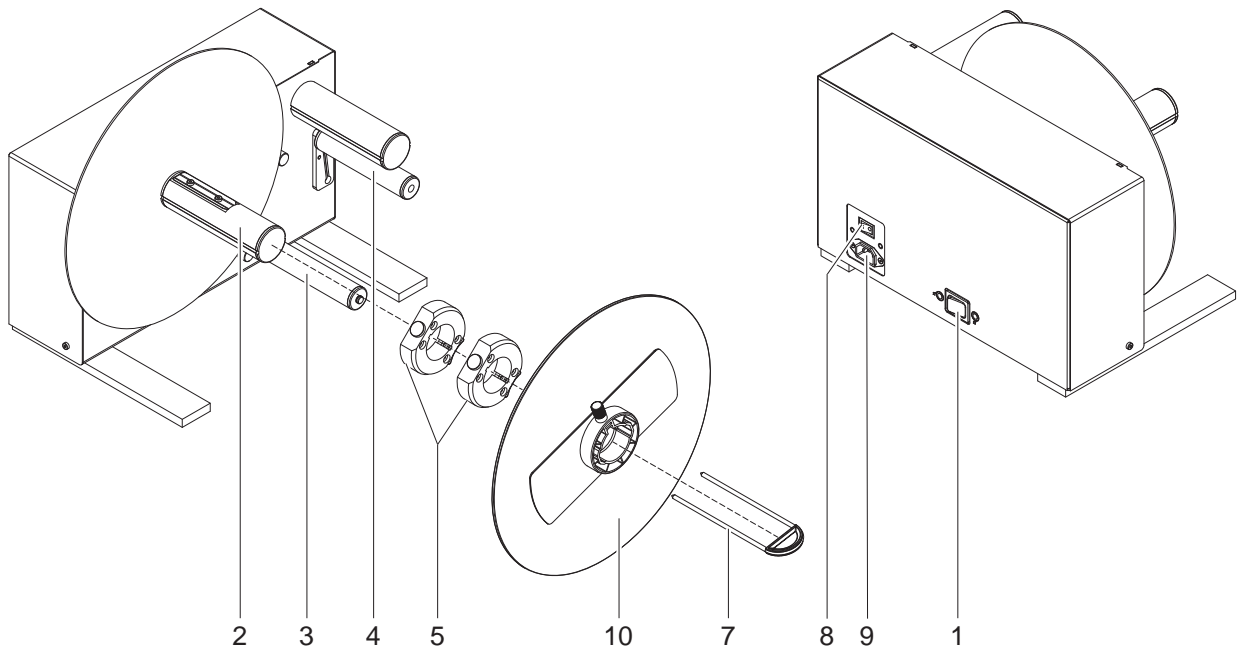

Figure 2 Overview ERx/300

- 1 Switch Winding Direction
- 2 Rewind Axle
- 3 Roller
- 4 Guide Axle
- 5 Rewind Adapter

- 6 Plate ER4/210
- 7 Clamp
- 8 Power Switch
- 9 Power Input Module
- 10 Plate ERx/300

3.1 Contents of Delivery

- ▶ Check the external rewinder for damages in transit and completeness.

Contents of delivery:

- External Rewinder
- Clamp
- 2 Rewind Adapters
- Plate for ER4/210 or Plate for ERx/300
- Power Cable
- Documentation



Note!

- ▶ Please keep the original packaging in case the device must be returned.

3.2 Connecting to Power Supply

The rewinder is equipped with a wide range power unit (100-240 V~), so it is possible to use the printer both with a voltage of 230 V~/50 Hz and with a voltage of 115 V~/60 Hz without changes.



Caution!

Risk of injury by rotating parts!

- ▶ Ensure that the power switch (1) is in position „O“ (OFF) before connecting the printer to a power supply !

When switching on the Rewinder starts immediately without or with loose material.

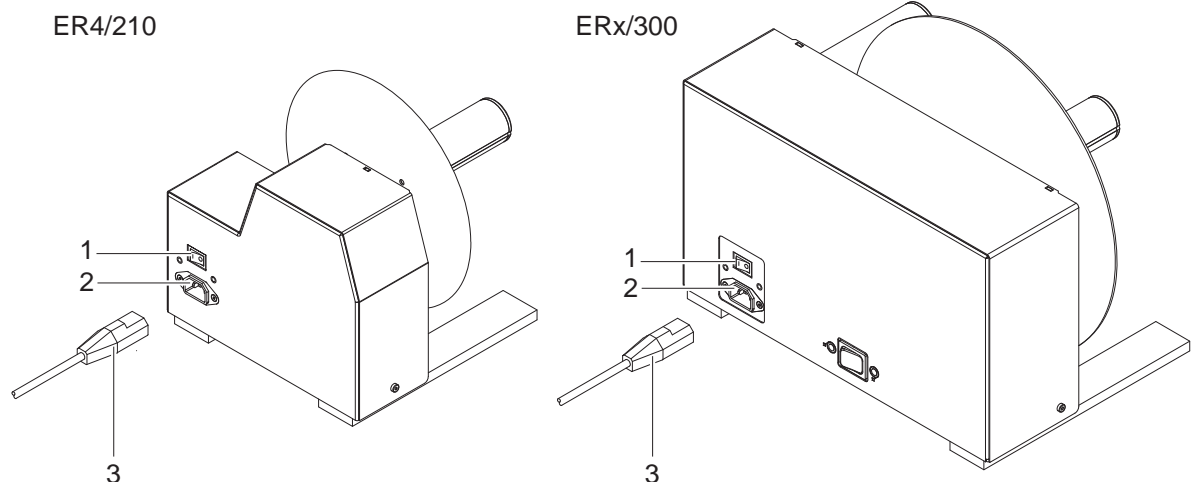

Figure 3 Connecting to power supply

- ▶ Connect the supplied power cable (3) to the power input module (2) and to a grounded outlet.

4.1 Setting the Winding Direction

With the setting of the winding direction it is possible to rewind the labels inside or outside.



Attention!

Risk of gear defect!

► **Switch off the device before changing the winding direction.**

ER4/210

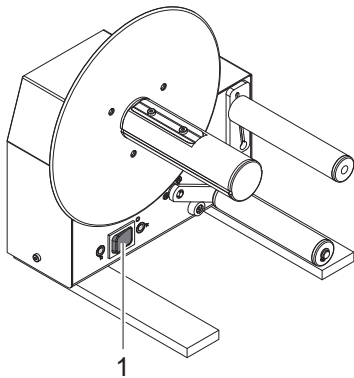

ERx/300

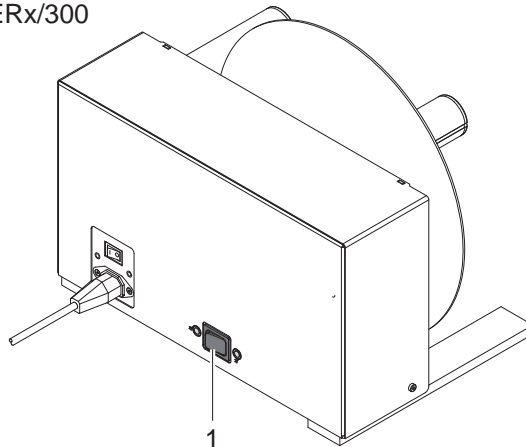

Figure 4 Setting the winding direction

► Select the winding direction with the switch (1):

	ER4/210	ERx/300
Rewinding with labels inside		
Rewinding with labels outside		

4.2 Adjusting the Guide Axle

Depending on the used printer the guide axle should be adjusted so that the label strip is led horizontally from the printer to the rewriter.

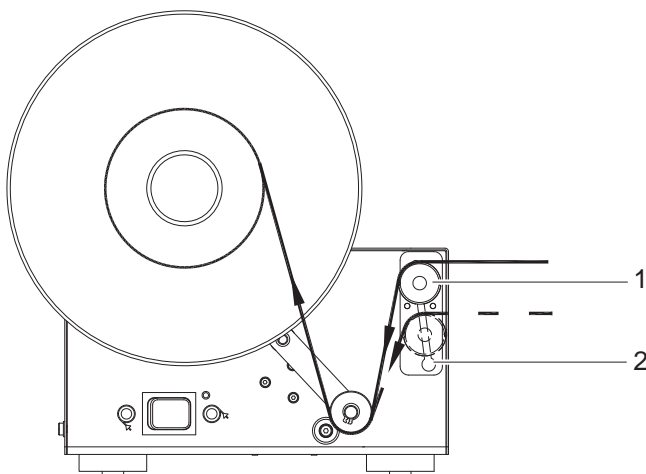

1. Loosen the guide axle (1) by turning it counterclockwise.
2. Move the axle in the guide plate (2) to the desired position.
3. Fasten the guide axle (1) by turning it clockwise.

Figure 5 Adjusting the guide axle

5.1 Rewinding Directly onto the Rewind Axle



Note!

- ▶ Remove the spring (2) from the rewind axle!



Caution!

Risk of injury by rotating parts!

When switching on the rewinder starts immediately and winds until the material is tightened.

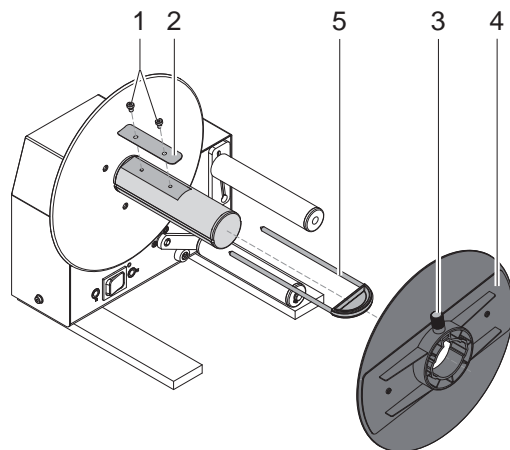

1. Loosen the screws (1) and remove the spring (2).



Note!

- ▶ Consider the selected winding direction:

- The broken line is valid for inside wound labels.
- The solid line is valid for outside wound labels.

2. Feed the label strip over the guide axle (9) and under the roller (8) to the rewind axle (7).



Note!

- ▶ When using a rewinder of the type ERx/300 for winding labels inside, lead the label strip additionally over the guide axle (10).

- ▶ Ensure that the label strip touches the disc (6).

3. Attach the label strip appropriately to the rewind axle by sliding the clamp (5) over the label strip with the clamp set in the groove of the rewind axle (7).

4. Slide the clamp (5) as far as possible towards the disc (6).

5. Slide the plate on ER4/210 (4) or ERx/300 (4) onto the rewind axle so that it slightly touches the label strip. The label strip must be able to move between the disc and the plate.

6. Tighten the knurled screw (3) on the plate.

7. Switch on the rewinder at the power switch.

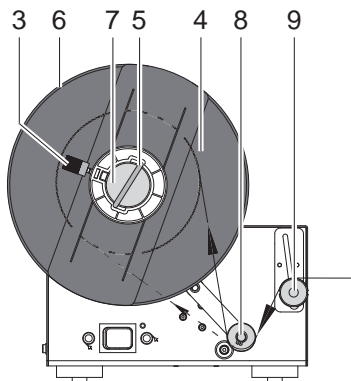

ER4/210

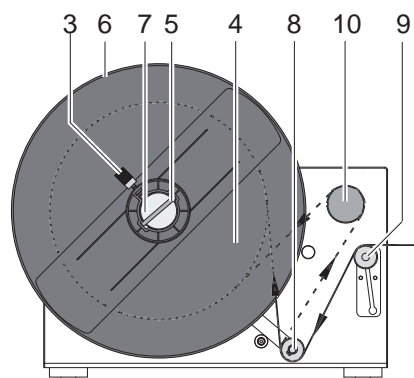

ERx/300

Figure 6 Rewinding Directly onto the Rewind Axle

5.2 Rewinding onto 40 mm (1.6 in) Cardboard Core



Note!

- ▶ Ensure that the spring (1) is mounted on the rewind axle (2)!
- ▶ Consider that the cardboard core (3) should be about 1 mm (0.04 in) broader than the label strip



Caution!

Risk of injury by rotating parts!

When switching on the rewinder starts immediately and winds until the material is tightened.

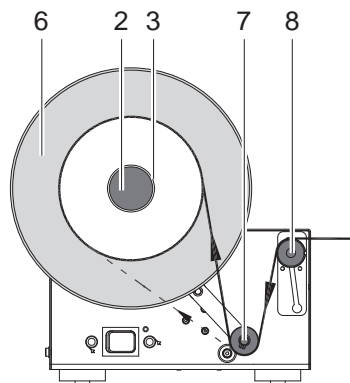
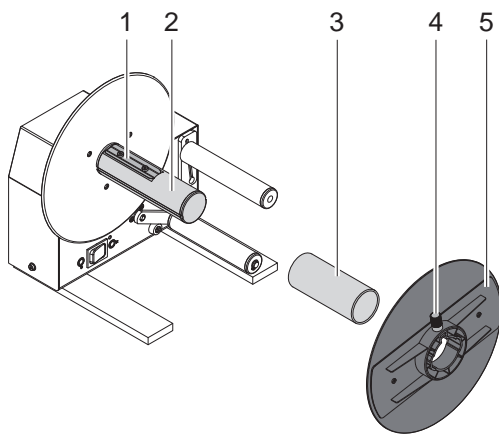

ER4/210

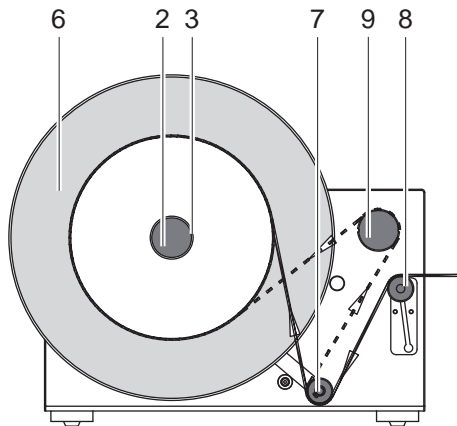

ERx/300

1. Put the cardboard core (3) on the rewind axle (2).



Note!

- ▶ Consider the selected winding direction:

- The broken line is valid for inside wound labels.
- The solid line is valid for outside wound labels.

2. Feed the label strip over the guide axle (8) and under the roller (7) up to the cardboard core (3).



Note!

- ▶ When using a rewinder of the type ERx/300 for winding labels inside, lead the label strip additionally over the guide axle (9).
- ▶ Ensure that the label strip touches the disc (6).

3. Affix the end of the label strip with consideration of the selected rewinding direction to the cardboard core using adhesive tape or label.

4. Slide the plate (5) with the knurled screw outward onto the rewind axle until it stops.



Note!

- ▶ When using small labels it is possible that the cardboard core does not cover the spring over the whole length. In this case the groove on the plate must be aligned so that it fits to the spring of the rewind axle.

5. Tighten the knurled screw (4) on the plate.

6. Switch on the rewinder at the power switch.

Figure 7 Rewinding onto 40 mm cardboard core

5.3 Rewinding onto 76 mm (3 in) Cardboard Core



Note!

- ▶ Remove the spring from the rewind axle!
- ▶ Consider that the cardboard core (3) should be about 1 mm (0.04 in) broader than the label strip.



Caution!

Risk of injury by rotating parts!

When switching on the rewinder starts immediately and winds until the material is tightened.

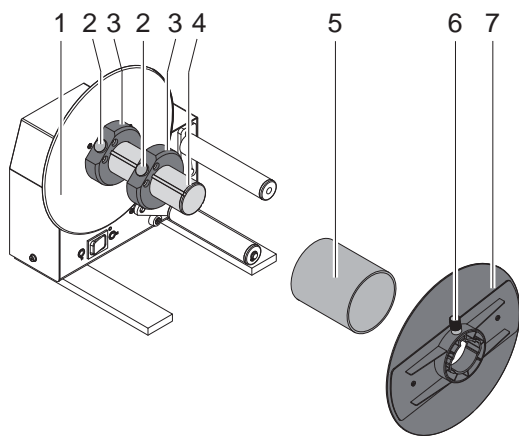

1. Put the first rewind adapter (3) onto the rewind axle (4) and slide it up to the disc (1) until it stops. Make sure that the knurled screw (2) of the rewind adapter is led in the groove of the rewind axle. Tighten the knurled screw (2).
2. Put the second rewind adapter (3) onto the rewind axle (4) and slide it towards the first adapter until the clearance between the outer edge of it and the disc (1) is a little less than the width of the cardboard core. Tighten the knurled screw (2).
3. Put the cardboard core (5) on the rewind axle (2).



Note!

▶ Consider the selected winding direction:

- The broken line is valid for inside wound labels.
- The solid line is valid for outside wound labels.

4. Feed the label strip over the guide axle (9) and under the roller (8) up to the cardboard core (5).



Note!

▶ When using a rewinder of the type ERx/300 for winding labels inside, lead the label strip additionally over the guide axle (10).

▶ Ensure that the label strip touches the disc (1).

5. Affix the end of the label strip with consideration of the selected rewinding direction to the cardboard core using adhesive tape or label.
6. Slide the plate (7) with the knurled screw outward onto the rewind axle until it stops.
7. Tighten the knurled screw (6) on the plate.
8. Switch on the rewinder at the power switch.

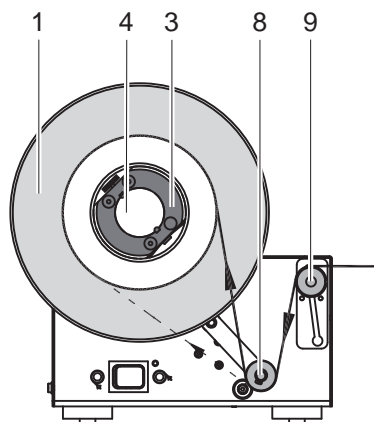

ER4/210

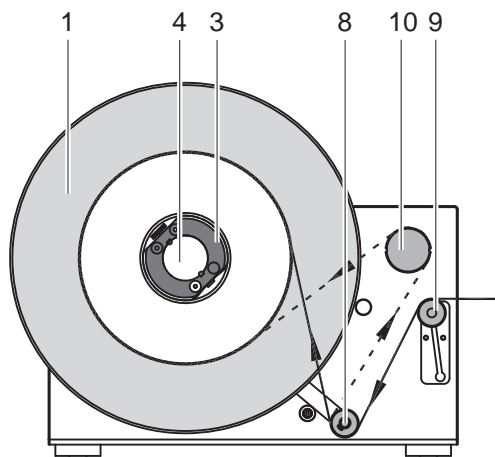

ERx/300

Figure 8 Rewinding onto 76 mm cardboard core

6.1 EU Declaration of Conformity



cab Produkttechnik
GmbH & Co KG
Wilhelm-Schickard-Str. 14
D-76131 Karlsruhe
Germany

EU Declaration of Conformity

We declare herewith that as a result of the manner in which the device designated below was designed, the type of construction and the devices which, as a result have been brought on to the general market comply with the relevant fundamental regulations of the EU Rules for Safety and Health. In the event of any alteration which has not been approved by us being made to any device as designated below, this statement shall thereby be made invalid.

Device:	External Rewinder
Type:	ER4 / ER6 / ER8
Applied EU Regulations and Standards	
Directive 2006/42/EC on machinery	<ul style="list-style-type: none"> • EN ISO 12100:2010 • EN ISO 13849-1:2015 • EN 60950-1:2006 +A11:2009+A12:2011+A1:2010+A2:2013
Directive 2014/30/EU relating to electromagnetic compatibility	<ul style="list-style-type: none"> • EN 55014-1:2006+A1:2009+A2:2011 • EN 55014-2:1997+A1:2001+A2:2008 • EN 61000-3-2:2014 • EN 61000-3-3:2013
Directive 2011/65/EU on the restriction of the use of certain hazardous substances in electrical and electronic equipment	<ul style="list-style-type: none"> • EN 50581:2012
Person authorised to compile the technical file :	Erwin Fascher Am Unterwege 18/20 99610 Sömmerda
Signature for the producer :	Sömmerda, 05.10.2017  Erwin Fascher Managing Director
cab Produkttechnik Sömmerda Gesellschaft für Computer- und Automationsbausteine mbH 99610 Sömmerda	

6.2 FCC

NOTE : This equipment has been tested and found to comply with the limits for a Class A digital device, pursuant to Part 15 of the FCC Rules. These limits are designed to provide reasonable protection against harmful interference when the equipment is operated in a commercial environment. The equipment generates, uses, and can radiate radio frequency and, if not installed and used in accordance with the instruction manual, may cause harmful interference to radio communications. Operation of this equipment in a residential area is likely to cause harmful interference in which case the user may be required to correct the interference at his own expense.